

F4

1500kg

Revolutionary

Pallet Truck



EP
Let's grow together

- All rounder for diverse applications
- Reduce operator effort and increase efficiency
- Small size (l2=400mm) and reduced weight (120kg)
- Up to 2 x 24V - 20Ah removable Li-ion batteries
- Removable storage compartment
- Available in different forks length and width



Manufacturer			EP
Model designation			F4
Drive			Electric
Load capacity	Q	kg	1500
Load center distance	c	mm	600
Service weight			kg
Length to face of forks	l2	mm	400
Overall width	b1/b2	mm	590/695
Fork dimensions	s/e/l	mm	55/150/1150
Turning radius	Wa	mm	1360
Max. gradeability, laden/unladen			%
Battery voltage/nominal capacity			V/Ah
			24/20

F4 -- All-rounder for diverse applications

F4 brings maximum flexibility in configurations for every application, from occasional to intensive usage, from standard to big loads. Featuring a two power slot design, F4 offers the option of two 24V/20Ah batteries to maximize uptime for full-time applications. The standard single-battery setting comes with a portable storage container to keep everything easily accessible on the go. Another option is the stabilizing wheels that allow to handle big loads while reducing the risk of falls and damages on uneven floors. Both options can be offered directly from the factory or as retrofit. Its versatility makes F4 an all-rounder, perfect for diverse tasks in the most cost effective way.



Battery option



Stabilizing wheel option

Why F Series ?

■ Platform-based design to maximise competitive advantage in the market

F series features the platform F, which simplifies the configuration of the truck and allows buyers to choose from 4 different chassis by application. The product design provides value and creates a flexible product strategy by introducing new equipment that meets various market requirements.

■ Cost-saving operations throughout the distribution cycle

4 units per box as standard wholesale supply reduces overall spending through the entire distribution process. F4 accommodates **176 units** in a 40' shipping container compared to 108 units of EPT12-EZ, that can reach as high as **30-40%** of ocean freight charges reduction.

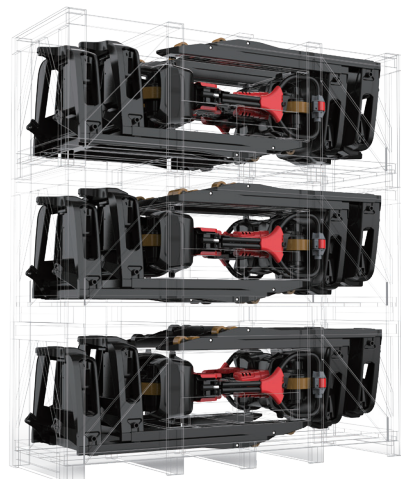

Li-Ion Pallet Truck 1.5T F4

Distinguishing mark	1.1	Manufacturer			EP
	1.2	Model designation			F4
	1.3	Drive			Electric
	1.4	Operator type			Pedestrian
	1.5	Load capacity	Q	kg	1500
	1.6	Load center distance	c	mm	600
	1.8	Load distance, centre of drive axle to fork	x	mm	950
	1.9	Wheelbase	y	mm	1180
	Service weight	2.1	Service weight		kg
2.2		Axle loading, laden front/rear		kg	480/1140
2.3		Axle loading, unladen front/rear		kg	90/30
Tyres/chassis	3.1	Tyre type			Polyurethane
	3.2	Tyre size, front			210mm×70mm
	3.3	Tyre size, rear			80mm×60mm
	3.4	Additional wheels (castor wheels)		mm	74mm×30mm
	3.5	Wheels, number front/rear (x=drive wheels)		mm	1x, —/4
	3.6.1	Tread width, front	b ₁₀	mm	—
	3.7.1	Tread width, rear	b ₁₁	mm	410 (535)
Dimensions	4.4	Lift height	h ₃	mm	105
	4.9	Height of tiller handle in drive position min./max.	h ₁₄	mm	750/1190
	4.15	Lowered height	h ₁₃	mm	88
	4.19	Overall length	l ₁	mm	1550
	4.20	Length to face of forks	l ₂	mm	400
	4.21	Overall width	b ₁ /b ₂	mm	590 (695)
	4.22	Fork dimensions	s×e×l	mm	55X150X1150
	4.25	Fork spread	b ₅	mm	560 (685)
	4.32	Ground clearance, center of wheelbase	m ₂	mm	25
	4.34.1	Aisle width for pallets 1000×1200 crossways	Ast	mm	2160
	4.34.2	Aisle width for pallets 800×1200 lengthways	Ast	mm	2025
	4.35	Turning radius	Wa	mm	1360
	Performance data	5.1	Travel speed, laden/unladen		km/h
5.2		Lifting speed, laden/unladen		m/s	0.017/0.020
5.3		Lowering speed, laden/unladen		m/s	0.058/0.046
5.8		Max. gradeability, laden/unladen		%	6/16
5.10		Service brake			Electromagnetic
Electric-engine	6.1	Drive motor rating S2 60 min		kW	0.75
	6.2	Lift motor rating at S3 15%		kW	0.5
	6.4	Battery voltage/nominal capacity		V/Ah	24/20
	6.5	Battery weight		kg	5
	6.6	Energy consumption according to DIN EN 16796		kWh/h	0.18
	6.7	Turnover output according to VDI 2198		t/h	60
	6.8	Turnover efficiency according to VDI 2198		t/kWh	333.33
	Addition data	8.1	Type of drive control		
10.5		Steering design			Mechanical
10.7		Sound pressure level at the driver's ear		dB(A)	74

If there are improvements of technical parameters or configurations, no further notice will be given.
The diagram shown may contain non-standard configurations.

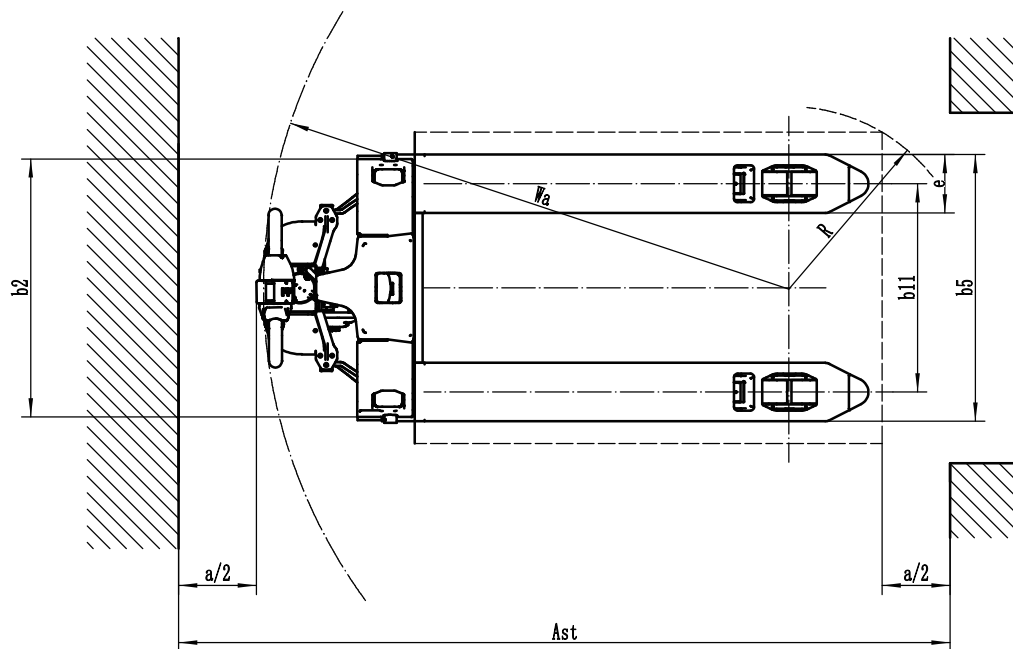
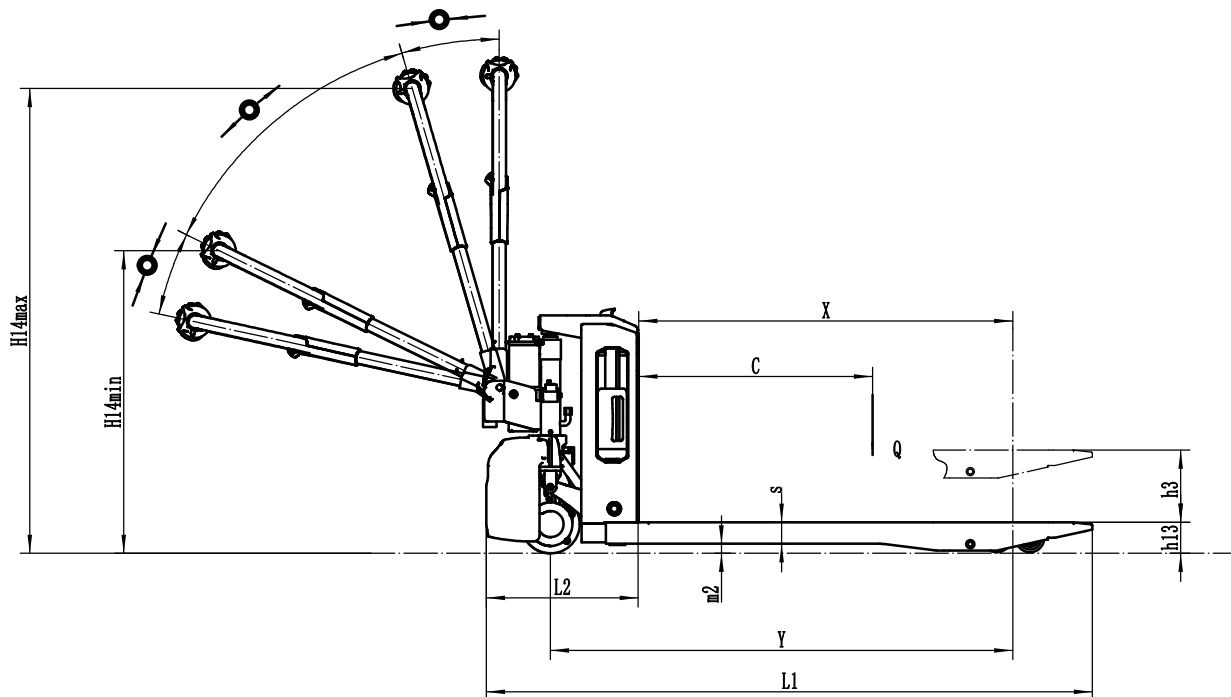

Option:

No.	Optional items	F4
1.1	Fork dimension	●1150*560○900*560○1000*560○1220*560○1350*560○1500*560 ○900*685○1000*685○1150*685○1220*685○1350*685○1500*685
1.3	Fork lowered height	●80
1.6	Drive cover off the ground	●55mm
2.1	Load wheel type	●Double○Single
2.2	Load wheel material	●PU
2.3	Drive wheel material	●PU
2.7	Battery capacity	●20AH×1○20AH×2○20AH×3○20AH×4
2.8	Charger	●24V-5A external○24V-10A external○24V-4A external DC-DC
2.9	Battery indicator	●Without time
2.16	handle head type	●Hands small handle head○ET Hands big handle head
3.3	Castor wheels	●No○Yes and not customized
3.12	Buzzer	●Yes and not customized
3.16	Turtle speed	●Yes and not customized
4.8	Drive assembly	●Yes and not customized
5.2	Charger base	●No○Yes and not customized
Note: ●Standard ○ Optional - Inconformity		